

PODVOZOK Y 25 Ls(s)d1 (Tatragagónka, a.s. Poprad)



PODVOZOK Y 25 Ls(s)d1

Používa sa napríklad na: Sgnss, Sggrss (kĺbový), Sggmrss/IS90 (kĺbový), Scnss (ACTS) atď.



PODVOZOK Y 31 Li (Tatravagónka, a.s. Poprad)

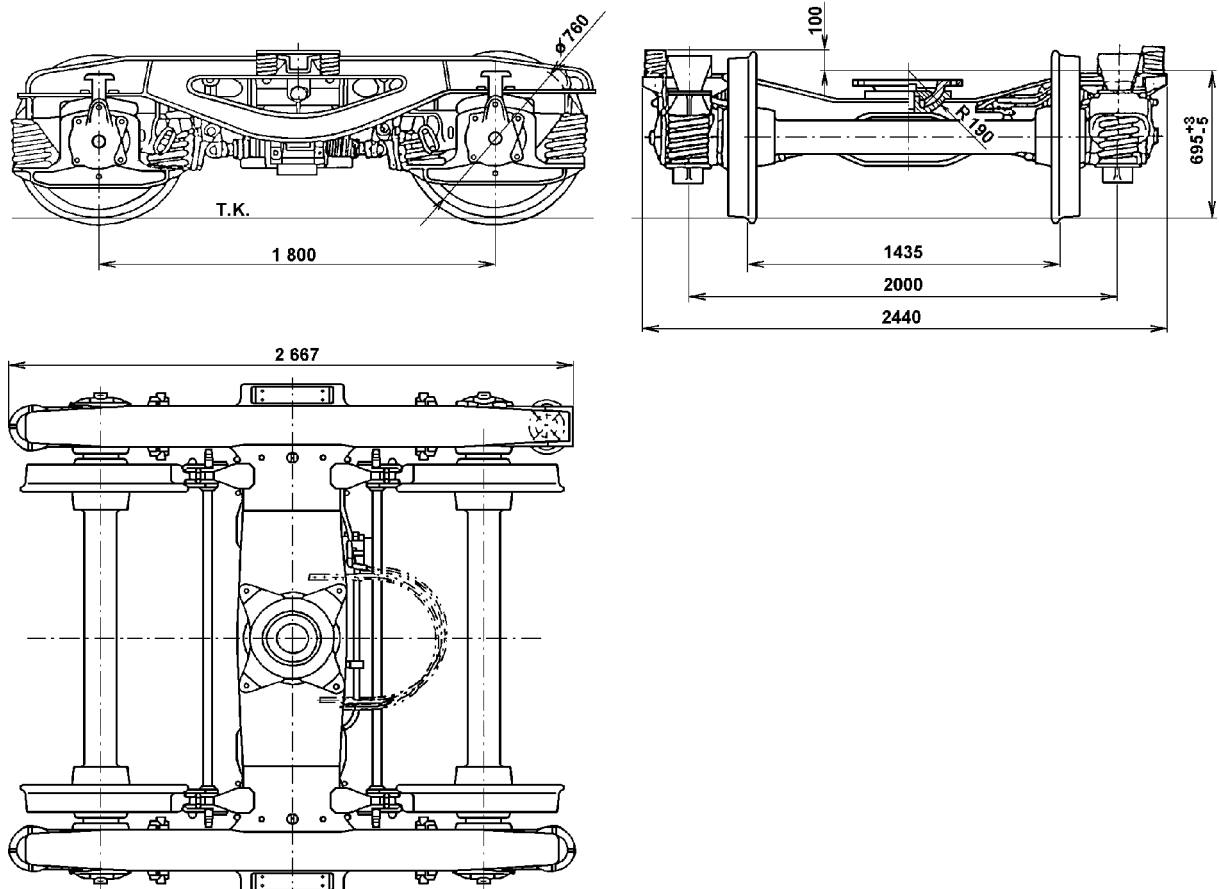

PODVOZOK Y 31 Lif (Tatravagónka a.s. Poprad)

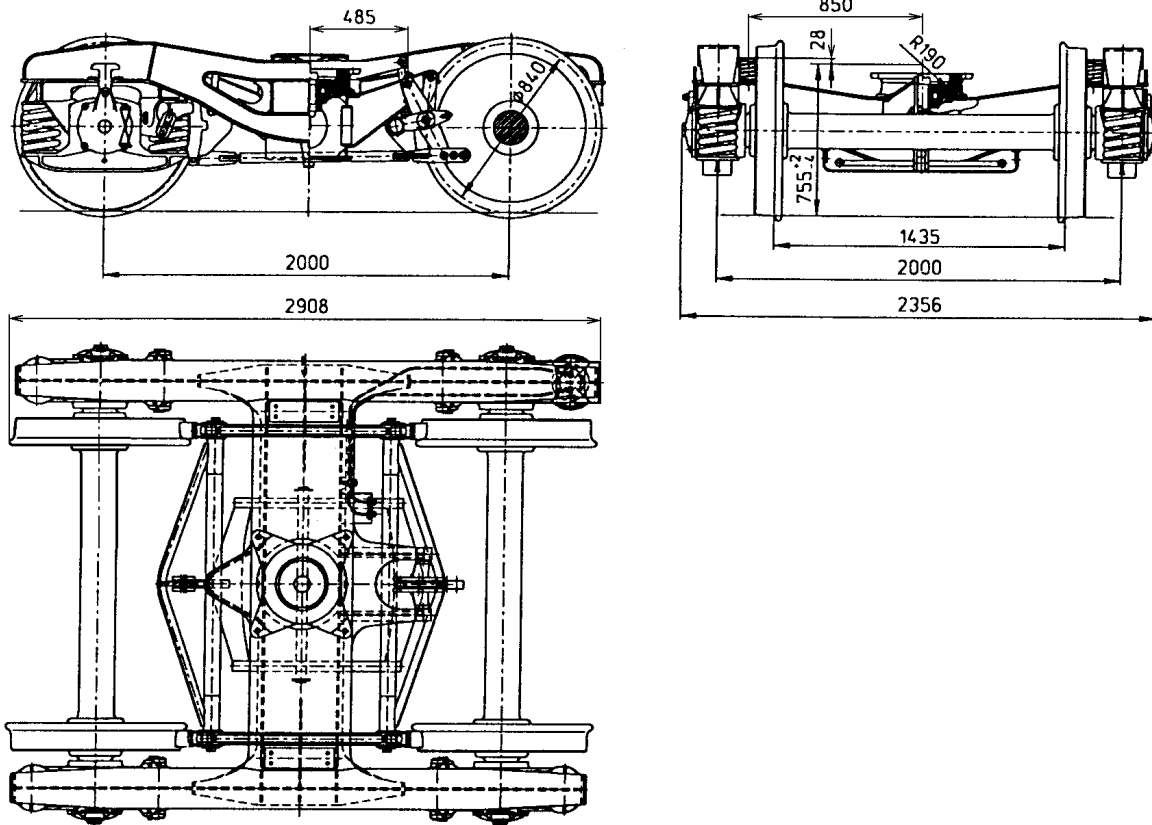

PODVOZOK Y 33 (Tatravagónka, a.s. Poprad)

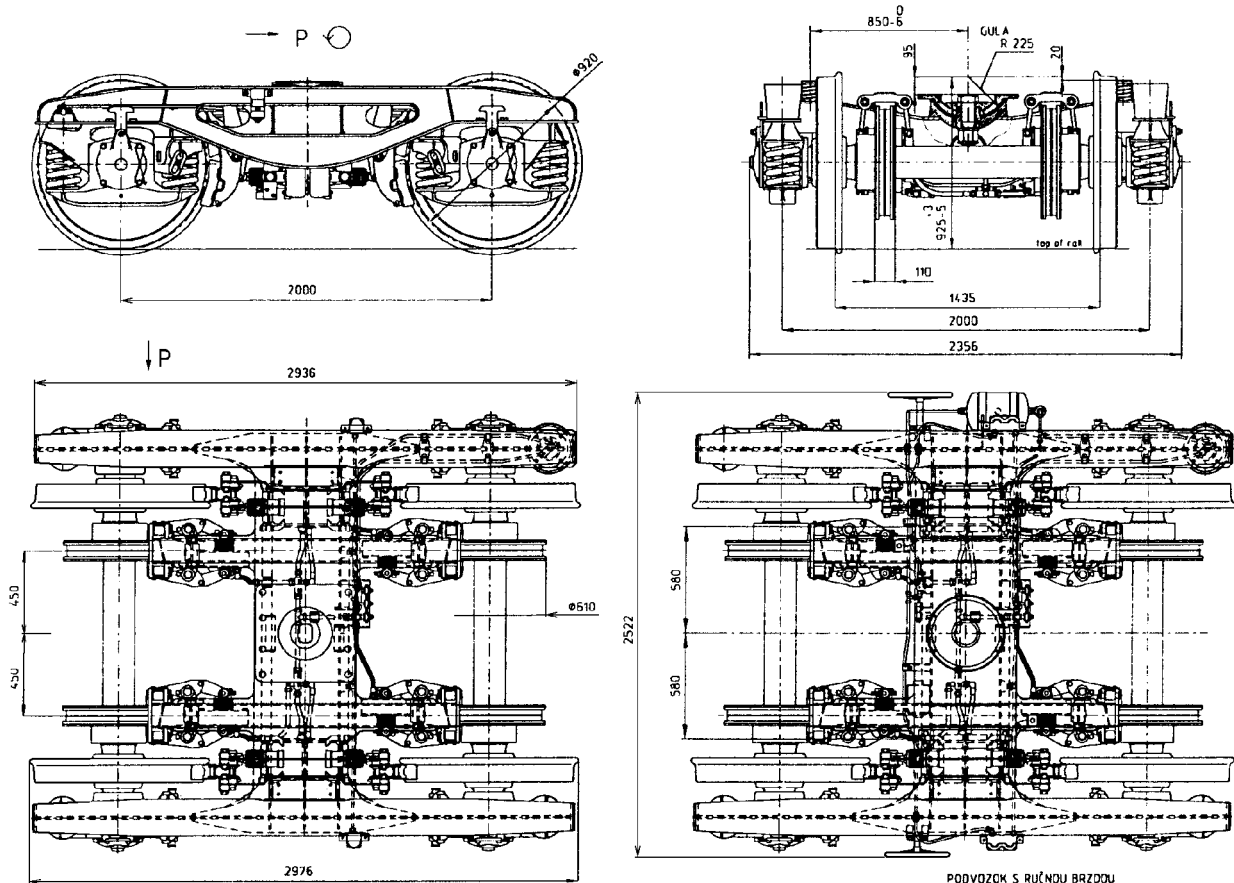

PODVOZOK Y 25 LasA (Tatravagónka a.s. Poprad)

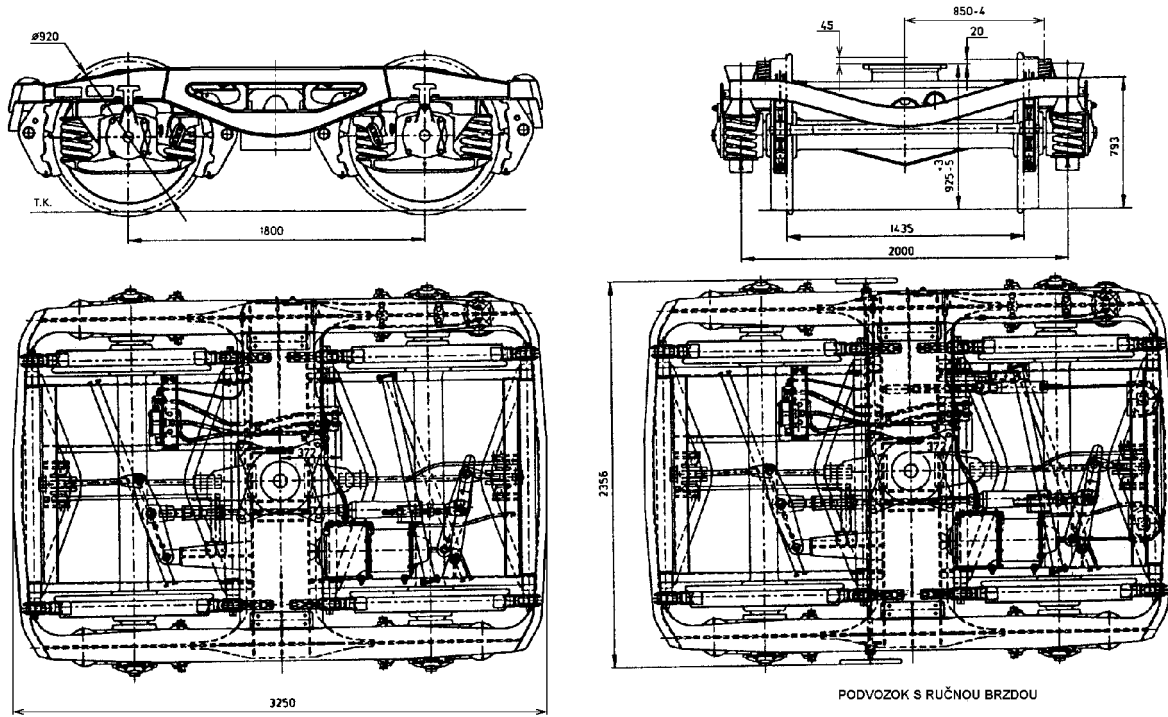

PODVOZOK Y 25 Ls(s)i1, Y 25 Ls(s)i1f (Tatravagónka, a.s. Poprad)

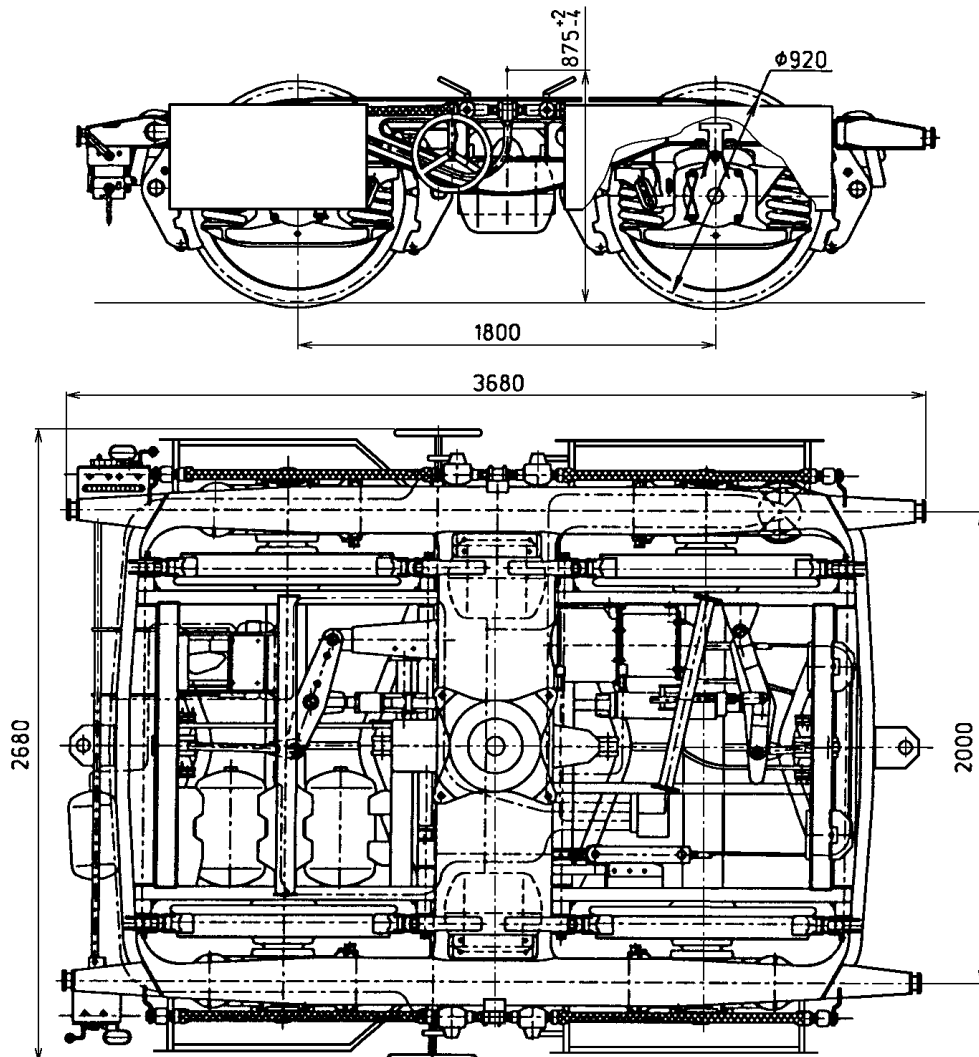

PODVOZOK Y 25-RRR PRE ROAD RAILER (Tatravagónka a.s. Poprad)



**ULOŽENIE KONCOV PODVOJNÝCH NÁVESOV NA STREDOVÝ
PODVOZOK S ADAPTÉROM - SYSTÉM CODA-E**



PODVOZOK SO STREDOVÝM ADAPTÉROM - SYSTÉM CODA-E



OTVOR V SPODKU PODVOJNÉHO NÁVESU PRE ULOŽENIE GUL'OVÉHO ČAPU ADAPTÉRA - SYSTÉM CODA-E

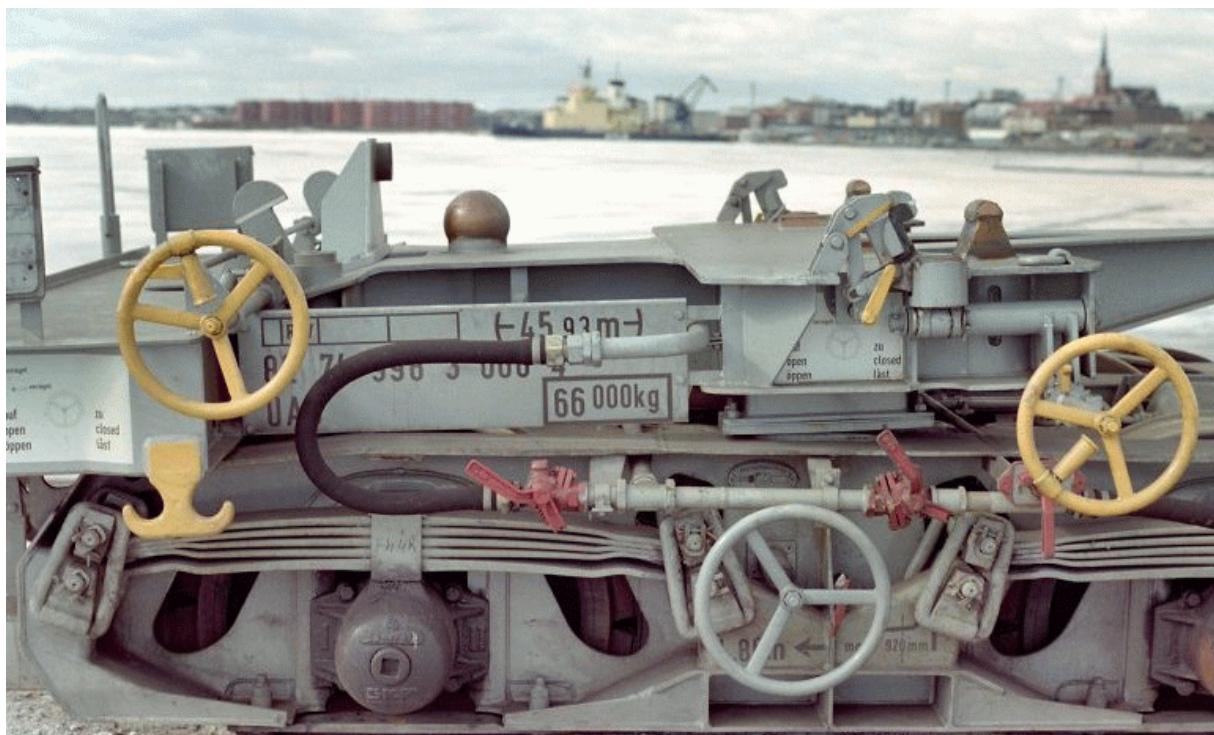

DETAIL PODVOZKU S KONCOVÝM ADAPTÉROM - SYSTÉM CODA-E

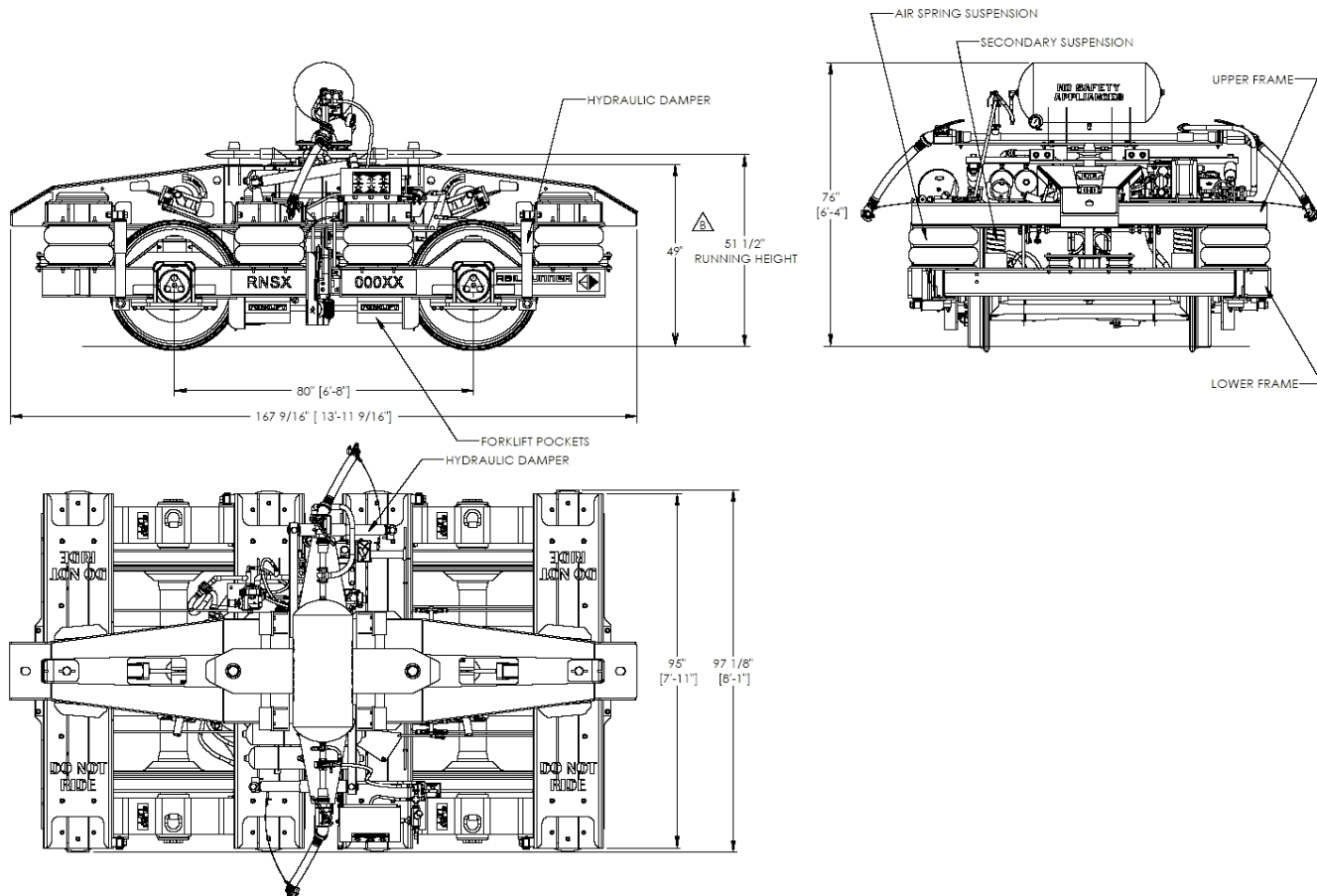

ROZMEROVÝ NÁČRTOK STREDOVÉHO PODVOZKU SYSTÉMU RailRunner (USA)



VZHĽAD STREDOVÉHO PODVOZKU - SYSTÉM RailRunner (USA)



ZOSTAVOVANIE VLAKOVEJ SÚPRAVY SYSTÉMU RailRunner (USA)



VLAKOVÁ SÚPRAVA RailRunner S KONCOVÝM PODVOZKOM



KONCOVÝ PODVOZOK PRE ZADNÉ ČELO NÁVESU SYSTÉMU Breda Carro Bimodale (Taliansko)



STREDOVÝ PODVOZOK S NALOŽENÝMI NÁVESMI (Breda Carro Bimodale)

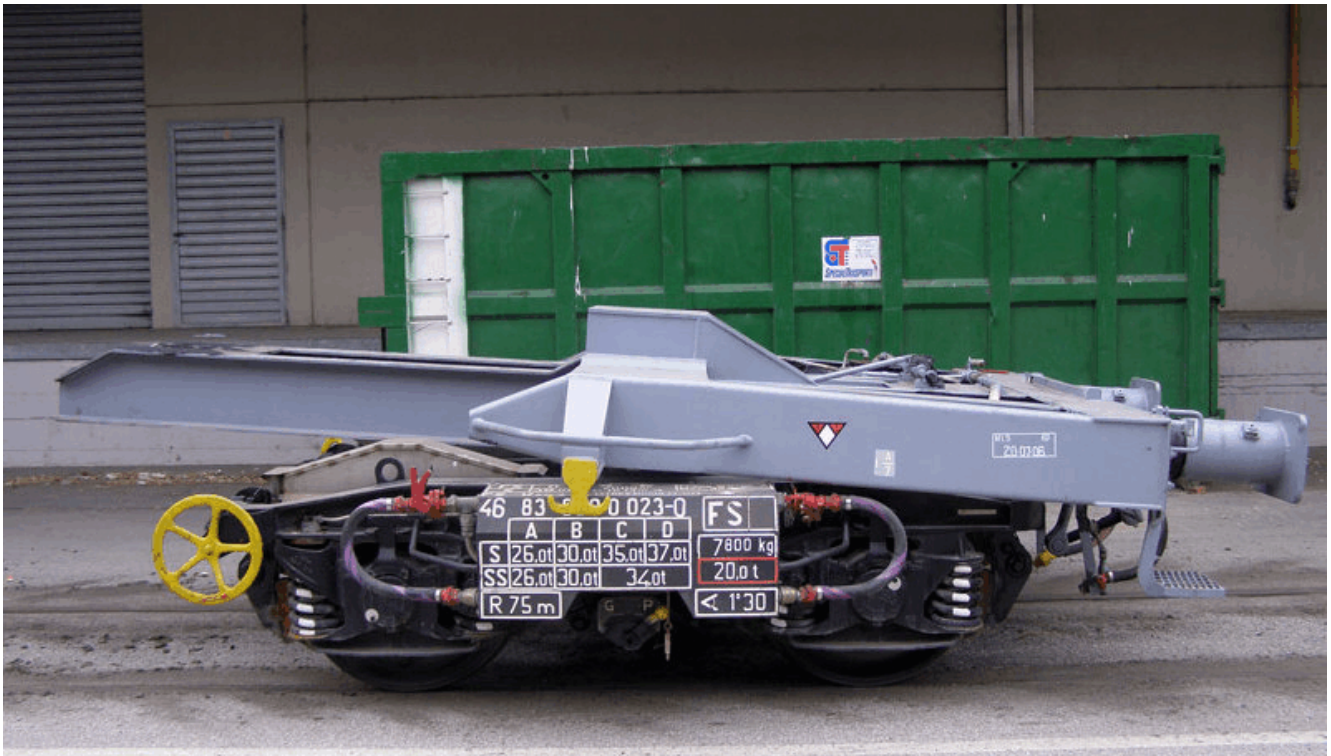

KONCOVÝ PODVOZOK PRE PREDNÉ ČELO NÁVESU SYSTÉMU Breda Carro Bimodale (Taliansko)



STREDOVÝ PODVOZOK S ADAPTÉROM PRE PREDNÝ KONIEC NÁVESU (Breda Carro Bimodale)

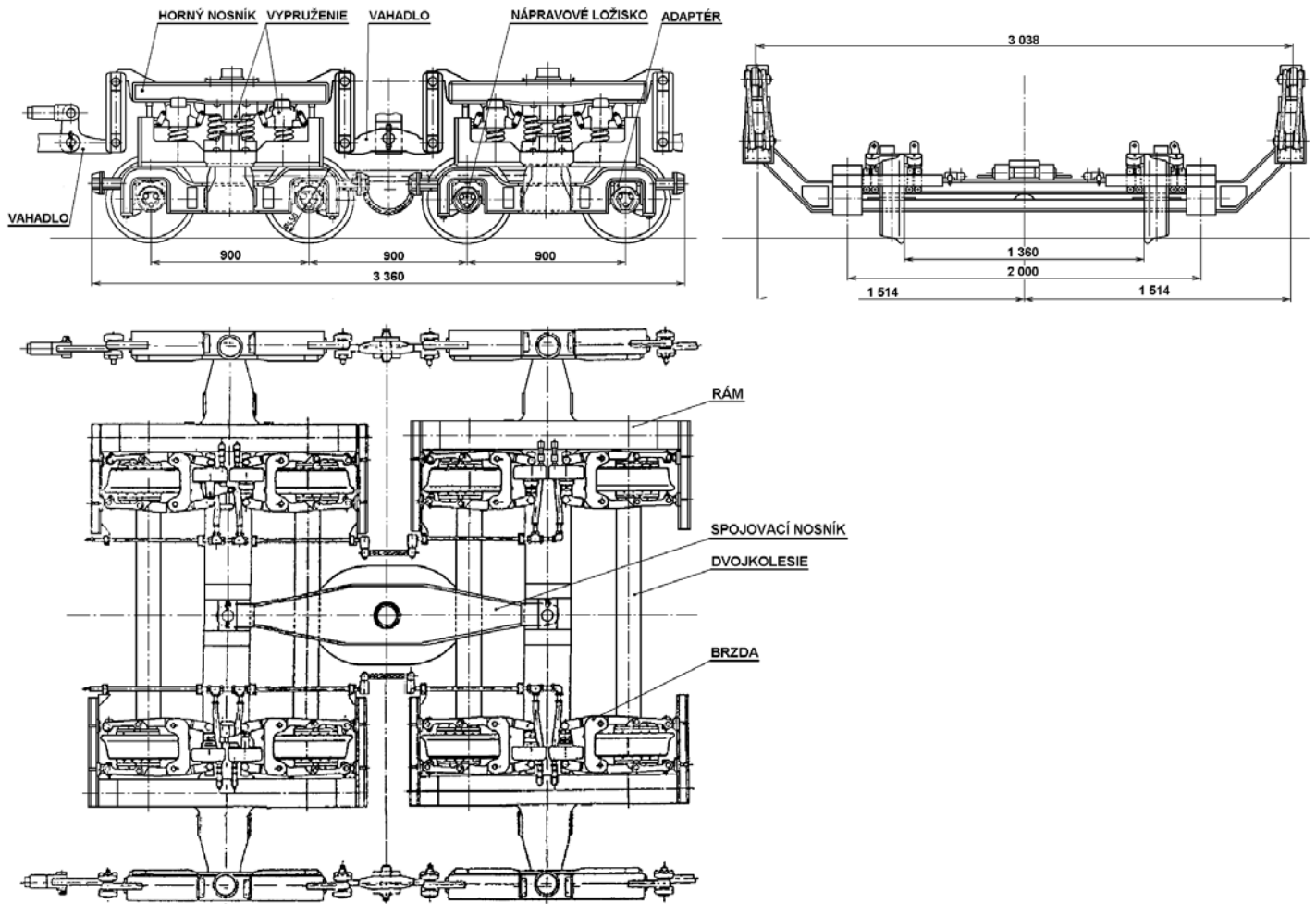

NÁČRTOK 4-NÁPRAVOVÉHO PODVOZKU RoLa



POHĽAD NA SEKUNDÁRNE VYPRUŽENIE PODVOZKU RoLa

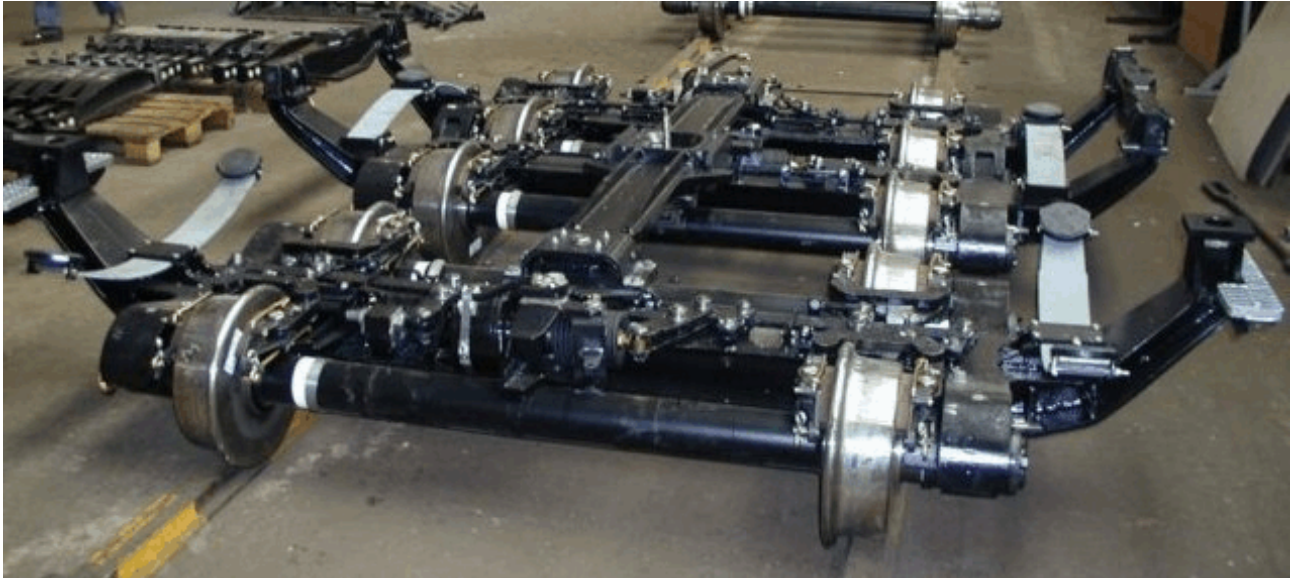

5-NÁPRAVOVÝ PODVOZOK RoLa



PRIEČNIK PODVOZKU RoLa

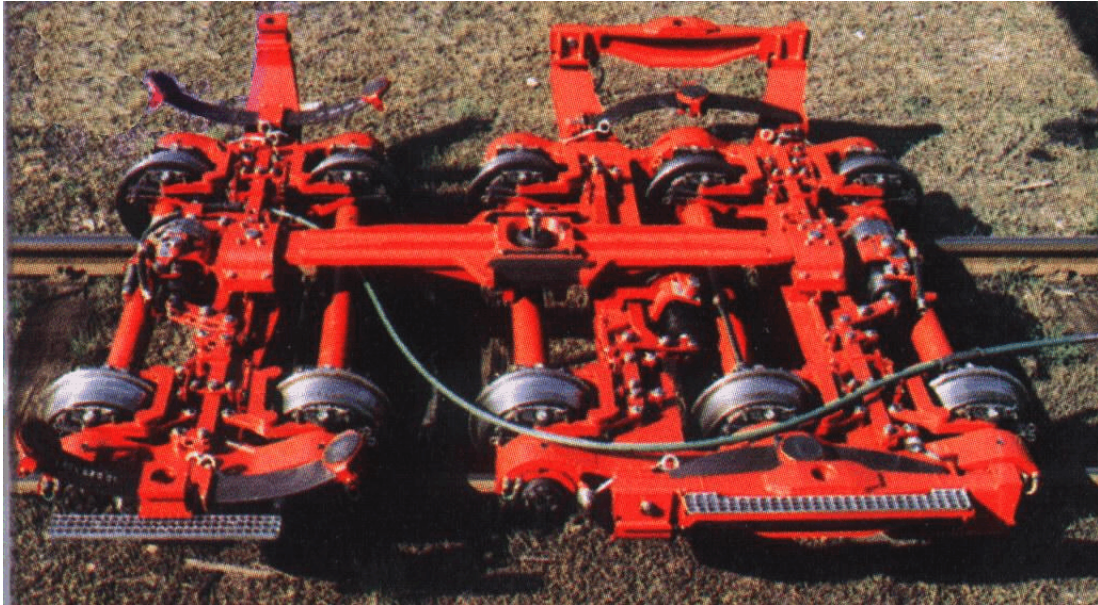

5-NÁPRAVOVÝ PODVOZOK RoLa

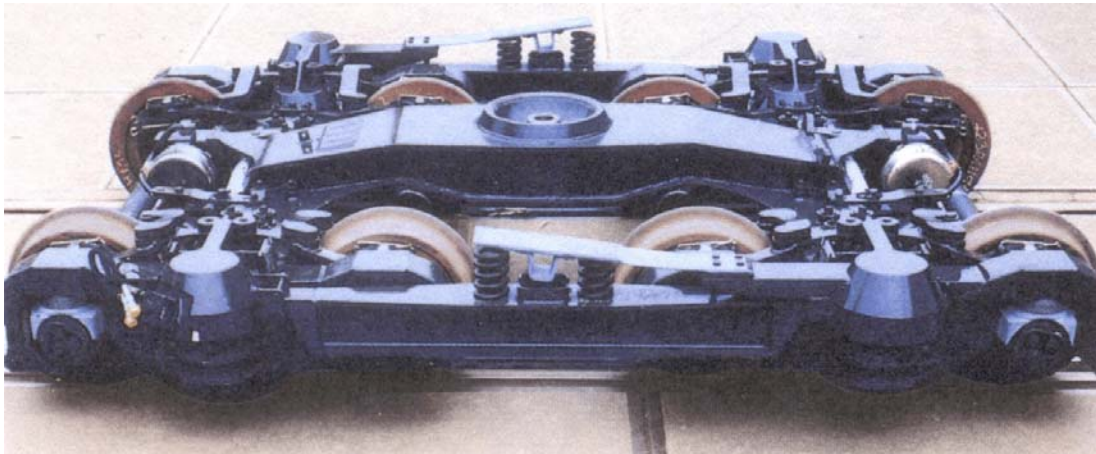

4-NÁPRAVOVÝ PODVOZOK RoLa (Talbot)

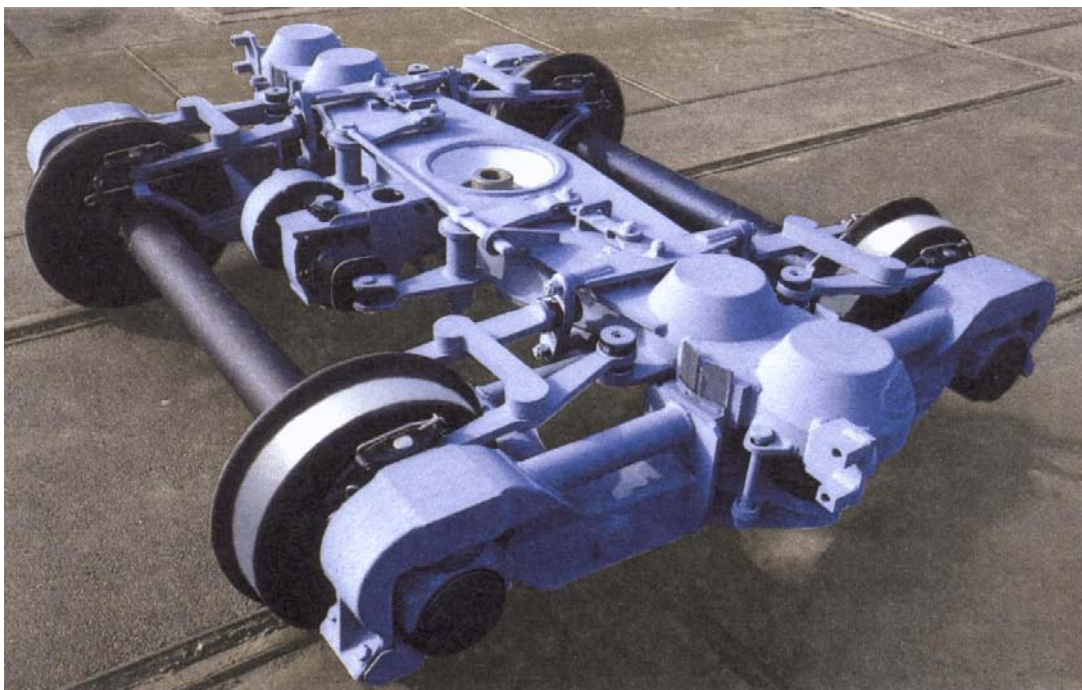

ČASŤ PODVOZKU RoLa (Talbot)